

MBT9600

FOUR-WIRE MODEM

FOR

TELEPROTECTION APPLICATIONS

Instruction Manual

September 1997

DM44-VER01

Pulsar
Technologies, Inc.

*4050 NW 121st Avenue
Coral Springs, FL 33065
1-800-785-7274*

Printed September 1997



IMPORTANT

We recommend that you become acquainted with the information in this manual before installing your new MBT9600 Four-Wire Modem. Failure to do so may result in damage to the modem or relay equipment, and may affect the equipment warranty.

PULSAR does not assume liability arising out of the application or use of any product or circuit described herein. PULSAR reserves the right to make changes to any products herein to improve reliability, function or design. Specifications and information herein are subject to change without notice. All possible contingencies which may arise during installation, operation, or maintenance, and all details and variations of this equipment do not purport to be covered by these instructions. If you desire further information regarding a particular installation, operation, or maintenance of equipment, please contact your local Pulsar Technologies, Inc. representative.

*Copyright ©
By Pulsar Technologies, Inc.
Published 1997
ALL RIGHTS RESERVED*

PULSAR does not convey any license under its patent rights nor the rights of others.

Preface

Scope

This manual describes the functions and features of the MBT9600 Four-Wire Modem. It describes the proper installation procedure for use with your SEL mirrored bit relay. It is intended primarily for use by engineers and technicians involved in the installation, alignment, operation, and maintenance of mirrored bit relays.

Equipment Identification

The modem's catalog order number — MBT9600 — is displayed on the top and bottom of the unit.

Warranty

Our standard warranty extends for 24 months after shipment. For all repaired units or advance replacements, the standard warranty is 90 days or the remaining warranty time, whichever is longer. Damage clearly caused by improper application, repair, or handling of the equipment will void the warranty.

Note: Tampering or removal of the MBT9600 cover will void the warranty.

Equipment Return & Repair Procedure

To return equipment for repair or replacement:

1. Call PULSAR at **1-800-785-7274**.
2. Request an **RMA number** for proper authorization and credit.
3. Carefully pack the equipment you are returning.

Repair work is done at the factory. The MBT9600 contains no user serviceable parts. When returning any equipment, pack it in the original shipping containers if possible. Be sure to use anti-static material when packing the equipment. Any damage due to improperly packed items will be charged to the customer, even when under warranty.

4. Make sure you include your return address and the RMA number on the package.
5. Ship the package(s) to:

Pulsar Technologies, Inc.
RMA Department
4050 NW 121st Avenue
Coral Springs, FL 33065

FIGURES

Figure No.		Page No.
1	MBT9600 Four-Wire Modem	1
2	MBT9600 Typical Application	1
3	MBT9600 DB9 Male Connector Pin Assignments	3

TABLES

Table No.		Page No.
1	MBT9600 Performance Specifications	3
2	MBT9600 Dimensions	3
3	MBT9600 Power Requirements	3
4	MBT9600 Audio Specifications	4
5	MBT9600 Environmental Specifications	4
6	MBT9600 Connector Specifications	4

Trademarks

All terms mentioned in this manual that are known to be trademarks or service marks are listed below. In addition, terms suspected of being trademarks or service marks have been appropriately capitalized. Pulsar Technologies, Inc. cannot attest to the accuracy of this information. Use of a term in this book should not be regarded as affecting the validity of any trademark or service mark.

SEL is a registered trademark of Schweitzer Engineering Laboratories, Inc.

MBT9600 Four-Wire Modem

Description

The MBT9600 is a high performance four-wire modem designed for use with Schweitzer Engineering Laboratories, Inc. protective relays using "mirrored bits" relay-to-relay logic communications. These relays use 4800 or 9600 bps asynchronous communications as an integral part of mirrored bit logic communications for protection, monitoring, and control.

The MBT9600 provides the following features and benefits:

- Compact size lets you mount it directly onto the relay's DB-9 (female) connector
- Powered by your serial port; no external power supply is required
- Auto configuring; no user setup required
- Fast retrain times (typically less than 1 second)
- Low absolute data delays (see Table 1)



Figure 1. MBT9600 Four-Wire Modem.

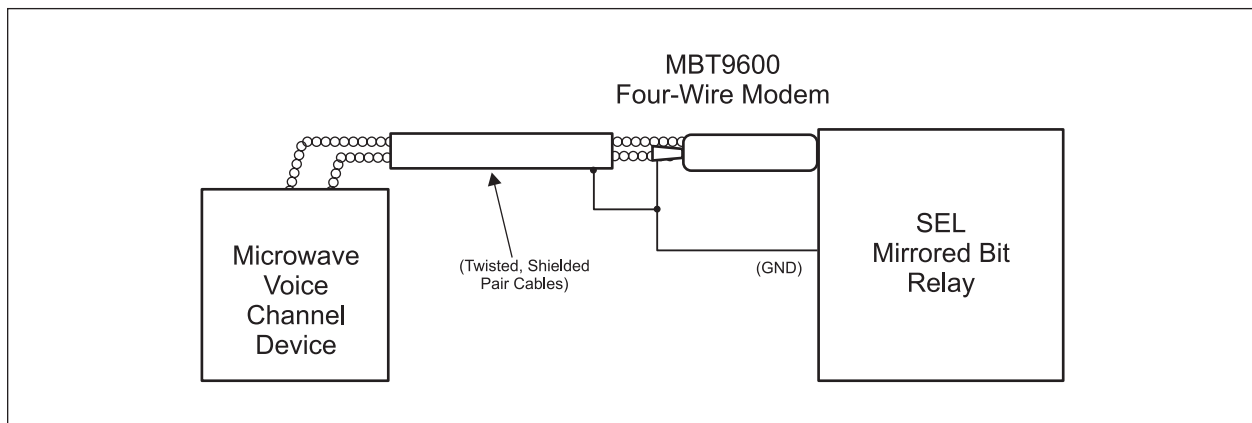

Figure 2. MBT9600 Typical Application.

Application

As noted previously, the MBT9600 is designed for use with SEL protective relays using "mirrored bits" relay-to-relay logic communications. Figure 2 shows a typical application.

The MBT9600 meets or exceeds all applicable ANSI, IEEE, and IEC standards.

Application specific features set the MBT9600 apart from conventional high-speed modems. Conventional modems typically have retrain times in excess of 15 seconds and absolute data delays in excess of 25 milliseconds. These critical parameters make conventional modems unusable for pilot relaying applications.

The MBT9600's compact size and ease of installation make it an ideal low-cost alternative to conventional audio tone teleprotection systems. The circuitry is ideally suited for use over private networks such as conventional voice channels over analog microwave.

Installation

These installation instructions tell you how to install the MBT9600 for use with an SEL mirrored bit relay and a microwave voice channel.

Hardware Installation/Connections

To install the MBT9600, complete the following four steps:

1. Plug the MBT9600's DB9 male connector into Serial Port 2 on the rear of the relay and tighten the retention screws finger tight.
2. Connect the two "transmit," or output, wires from the voice channel device to the "RX" terminals on the MBT9600 using twisted, shielded pair cables.

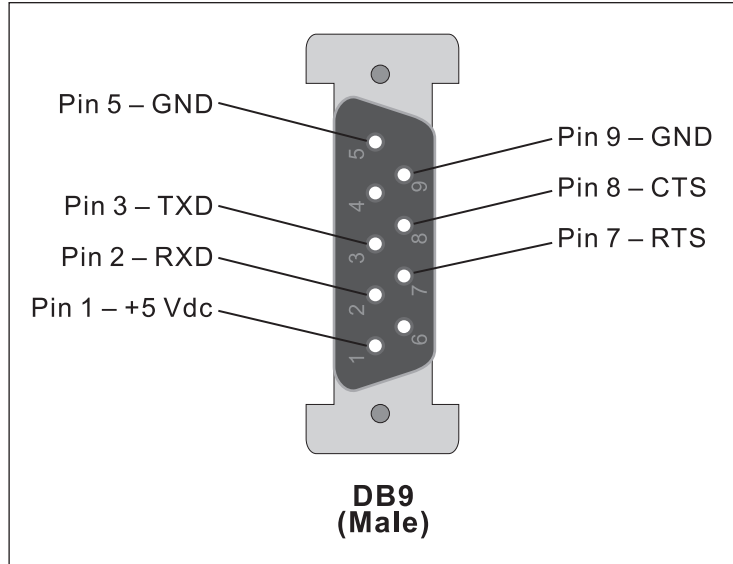

Figure 3. MBT9600 DB9 Male Connector Pin Assignments.

3. Connect the two "receive," or input, wires from the voice channel device to the "TX" terminals on the MBT9600 using twisted, shielded pair cables.
 4. Connect one end of a ground wire to the "Gnd" terminal on the MBT9600 and the other end to the "GND" terminal on the rear of the relay. Also connect the cable shield to the relay's GND terminal. **ALL OF THESE GROUNDS MUST BE CONNECTED BEFORE USE.**
- Note: Connect the cable shield to ground only at one end.
5. Once the system is in full operation with the communications path established,, Target 20 of the SEL 321 will read "ROK" indicating that the mirrored bits are working properly.

The MBT9600 is now ready for operation.

Ordering Information

The code for ordering the MBT9600 four-wire modem is **MBT9600**, as displayed on the top and bottom of the unit.

Specifications

The MBT9600's technical specifications are shown in Tables 1–6.

Table 1. MBT9600 Performance Specifications.

Data Rates	9600 or 4800 bps
Absolute delay*	<12 ms @ 9600 bps; <16 ms @ 4800 bps
Retrain Time	Typically < 1 Second

Table 2. MBT9600 Dimensions.

Width	.75" (1.90 cm)
Height	1.25" (3.18 cm)
Length	3.2" (8.13 cm) Projection mount

Table 3. MBT9600 Power Requirements.

Source	Pin 1 of the DB 9 connector
Voltage	+5 Vdc
Current	<125 milliamps

*Absolute delay is the time span from when a bit first enters a modem until it exits the adjacent modem. This time is exclusive of any communications system propagation delays.

Table 4. MBT9600 Audio Specifications.

Impedance	600 Ohms
Transmit Level	-9* dBm
Receive Level	-9* to -30 dBm
Audio Bandwidth	300-3400 Hz (4-wire circuit)
Minimum SNR	27 dB @ 9600 bps; 16 dB @ 4800 bps
Conditioning	C4 conditioning is required for leased circuits.

**Touch tone levels only*

Table 5. MBT9600 Environmental Specifications.

Temperature Range	-40 to +85° C
EMI	IEEE C37.90.2 / IEC 1000-2-2
Dielectric	ANSI C37.90 & C37.90.1 / IEC 1000-4-4 & IEC 255-22-1
ESD	IEC 1000-4-2

Table 6. MBT9600 Connector Specifications.

SEL Mirrored Bit Relay	DB9 Male
Microwave Voice Channel	Screw-type (5-position) compression terminal block, accepting up to 18 AWG wire